

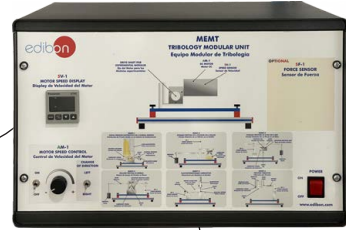

MEMT-UB. Drive Unit
for Tribological Tests



Electronic console

Required elements (at least one)
(Not included):



MEMT-1.
Radial Pressure Distribution in a
Journal Bearing

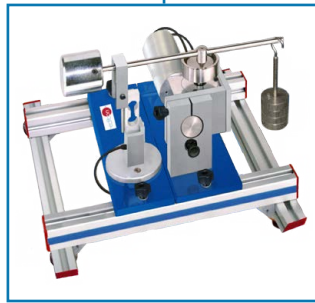

MEMT-3.
Dynamic Friction of a Pin on a Disc



MEMT-5.
Elastohydrodynamic Lubrication



MEMT-2.
Dynamic Friction of a Cylinder
on a Roller

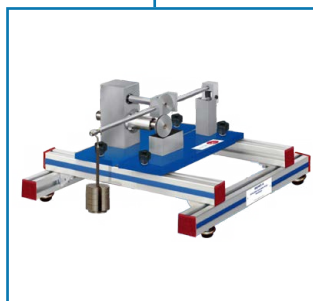

MEMT-4.
Rolling Friction in Wheels

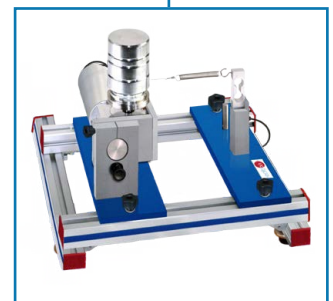

MEMT-6.
Friction Vibration



Certificate of Approval of the
Quality Management System



European Union Certificate
(total safety)



UL and CSA Regulations (All our products
are manufactured according to current UL and
CSA regulations)



Certificate of Approval of the
Environmental Management System



Worlddidac Association
Certificate of Membership

INTRODUCTION

Tribology is the science dedicated to the study of surfaces that interact in relative motion, and includes the study and application of the principles of friction, lubrication and wear. The tribology unit consists of surfaces of two components that move in contact with each other and with their environment.

Friction is the force that resists the relative movement of two solid surfaces sliding against each other. The resulting friction forces depend on the normal force and the friction coefficients of the solid surface.

Tribology is present in virtually all aspects of the machinery, engines and components of the industry in general. The most common tribological components are: Bearings, brakes and clutches, seals, piston rings and gears, cams, etc. Is crucial for modern machinery that uses rolling and/or sliding surfaces.

GENERAL DESCRIPTION

The Tribology Modular Unit, "MEMT", consists of a base unit with electronic console and a series of experimental units to investigate and visualize tribological phenomena.

MEMT-UB. Drive Unit for Tribological Tests.

This unit is common for the units type "MEMT".

It consists of a base unit and an electronic console:

The base unit consists of a drive unit formed by a DC motor with a shaft. The motor is mounted in a reduction gear, obtaining enough torque in the motor for a wide operation range. A force sensor is used to determine the moment of friction and is included in each experimental unit in which it is necessary to measure that friction force.

An electronic console allows to adjust the DC motor speed with a potentiometer and the motor direction of rotation, and to show the DC motor speed and the force applied in two digital displays.

This unit allows the study of different cases of rolling and sliding friction, and the pressure distribution in a journal bearing. The comprehensive range of units and friction pairings makes possible, among other things, to represent how the friction force is dependent on the contact surfaces except when proper lubrication is used.

The different experimental units are quickly and easily mounted and connected to the Drive Unit for Tribological Tests, "MEMT-UB", with electronic console, thanks to quick-clamping elements.

Required elements (at least one) (Not included):

MEMT-1. Radial Pressure Distribution in a Journal Bearing.

This unit allows the visualization of the radial pressure distribution in a journal bearing with hydrodynamic lubrication.

The "MEMT-1" unit consists of a journal bearing with hydrodynamic lubrication, a freely moving bearing housing with thirteen manometric tubes that allow to visualize the radial pressure distribution.

The journal bearing movement and the oil film can be seen through a transparent plastic bearing housing. The pressure distribution in the journal bearing is measured by thirteen manometric tubes using the height of each column of liquid.

The gap width can be adjusted by the movable bearing housing with a micrometer screw.

The lubricant that enables the visualization of pressure distribution in the journal bearing is contained in a tank. The distribution of pressure on the journal bearing can be determined at different speeds, loads and bearing gap width.

MEMT-2. Dynamic Friction of a Cylinder on a Roller.

This unit allows to demonstrate the friction forces between several cylinders of different materials and a roller under different lubrication conditions.

The "MEMT-2" unit consists of two levers that transmit a force applied by weights to a test pin to put it in contact with a disc coupled to a motor shaft that allow to demonstrate the friction forces between several friction test pins of different materials and the disc coupled to the motor shaft under different lubrication conditions.

Each test pin is made of different material and rubs against the external surface of a rotating steel disc coupled to the motor shaft under different lubrication conditions. There is a lubricant tank underneath the rotating disc.

Initially, a point contact is formed, as the wear increases it changes to a surface contact.

The speed of the rotating steel disc can be adjusted, and the test pins are loaded using two levers and a set of weights.

A force sensor measures the friction forces as a function of the pairs of friction materials, the speed of the rotating disc, the load and the lubrication conditions.

MEMT-3. Dynamic Friction of a Pin on a Disc.

This unit allows to study the friction forces between several vertical friction pins of different materials and a rotating friction disc. The end of each vertical pin is made of a different material and rubs against the rotating steel disc. The speed of the rotating disc can be adjusted. The contact pressure between the vertical pin and the rotating disc can be adjusted with a lever and a set of weights. The disc is enclosed in an open tank that can be filled with different lubricants. A force sensor measures the friction forces as function of the pairs of friction materials, the speed of the rotating disc, the load and the lubrication conditions.

MEMT-4. Rolling Friction in Wheels.

This unit allows to determine the slip forces between two rotating friction discs in contact. The slip between the discs is maintained constant by a gearbox. The pressure can be adjusted with a lever and a set of weights. The unit includes a tank for supplying lubricant. A force sensor measures the friction forces as a function of the load, the rotating speed and the lubricant. Several knurled screws enable to change the rotating friction discs easily.

MEMT-5. Elastohydrodynamic Lubrication.

This unit allows to investigate the thickness and characteristics of a lubricant film on a rolling sphere. The unit consists in a steel sphere and a driven glass disc. The sphere is pressed against the underside of the glass disc. The light from a reflected light microscope passes through the glass disc and the lubricant film at the point of contact; then, it is reflected from the surface of the sphere. The lubricant film thickness is determined visually from the colors of the interference rings produced. The microscope can be adjusted using a movable support, adjustable in x-y and has a focus adjustment. A defined pressure can be applied to the sphere. This pressure can be adjusted with a lever.

MEMT-6. Friction Vibration.

This unit allows to demonstrate the static friction, the sliding friction, the related friction vibrations and the slip-stick effects. Several weights are placed on a horizontally rotating friction disc. It is prevented from turning by a cord. This cord is coupled to force measuring devices with a force sensor via a tension spring. An open tank surrounds the friction disc to place different lubricants.

PROCESS DIAGRAM AND UNIT ELEMENTS ALLOCATION

Diagram of the Base Unit with Electronic Console

MEMT-UB. Drive Unit for Tribological Tests

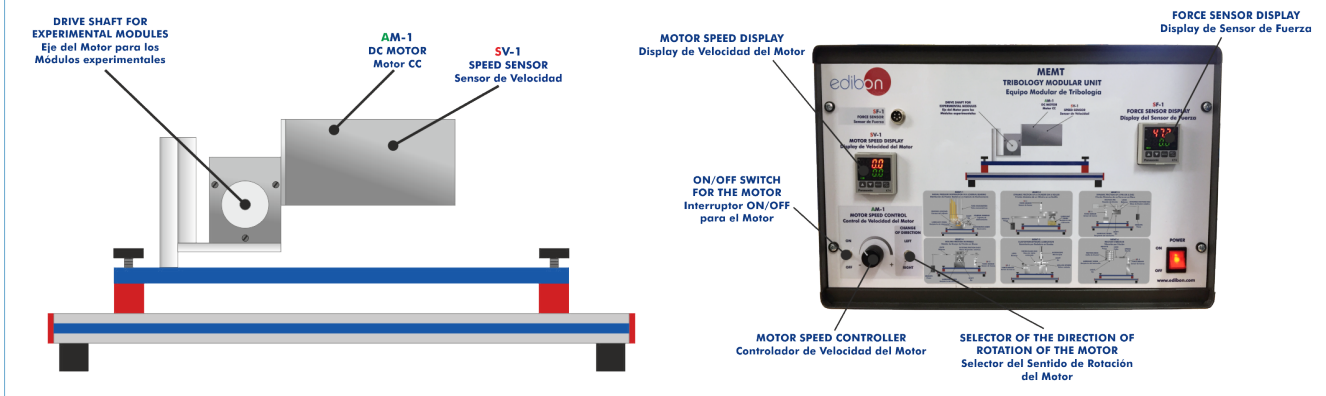

Diagrams of the Experimental Modules

MEMT-1. Radial Pressure Distribution in a Journal Bearing

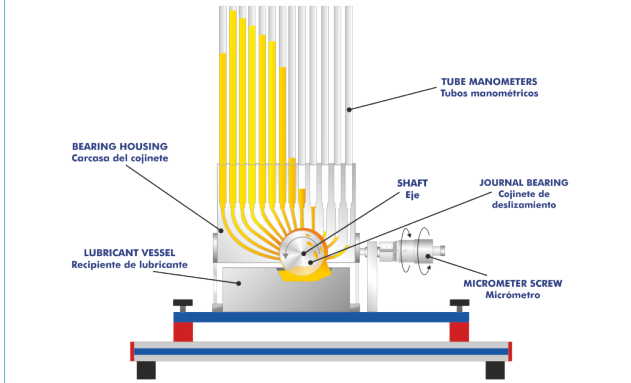

MEMT-2. Dynamic Friction of a Cylinder on a Roller

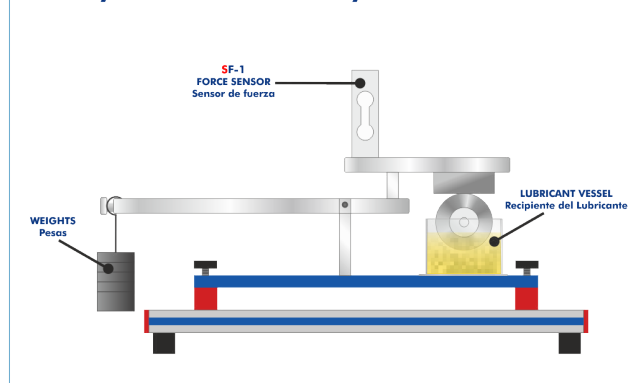

MEMT-3. Dynamic Friction of a Pin on a Disc

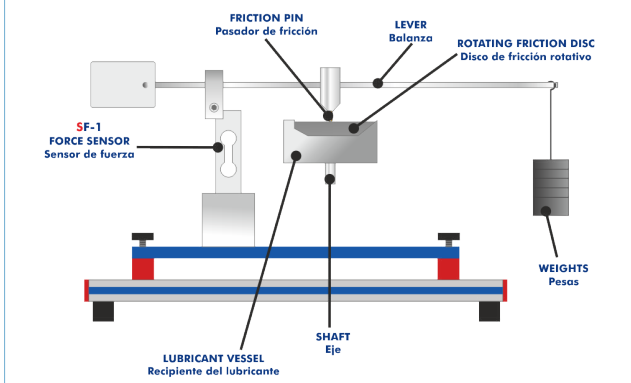

MEMT-4. Rolling Friction in Wheels

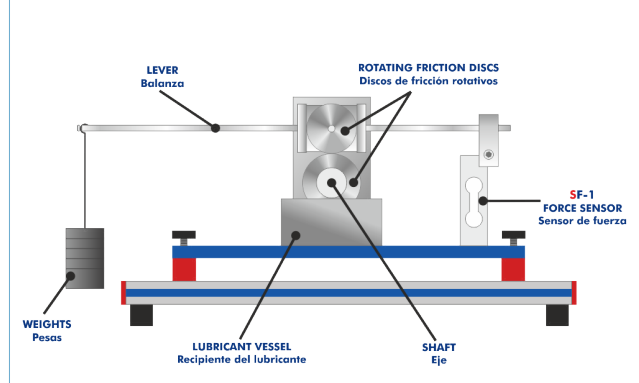

MEMT-5. Elastohydrodynamic Lubrication

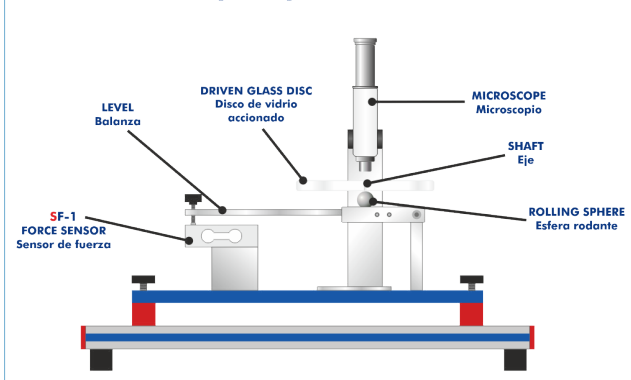

MEMT-6. Friction Vibration

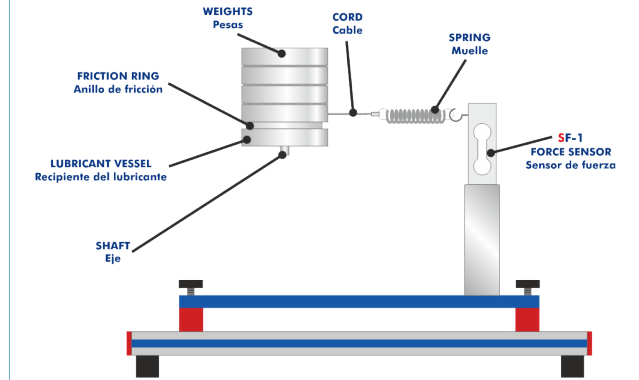

SPECIFICATIONS

MEMT-UB. Drive Unit for Tribological Tests.

Bench-top unit.

Anodized aluminum frame and panels made of painted steel.

Diagram in the front panel with distribution of the elements similar to the real one.

The drive unit consists of:

DC motor, electronically controlled:

Speed range: 0 – 3000 rpm.

Operating speed: 0 – 250 rpm.

Torque: 19 Nm approx.

Worm gear: $i=14.66$.

Electronic console:

Force sensor connection.

ON/OFF controller for the motor.

Motor speed controller.

Selector of the direction of rotation of the motor.

Digital display for the motor speed.

Digital display for the force sensor.

Cables and accessories, for normal operation.

Manuals: Required services, Assembly and Installation, Interface and Control Software, Starting-up, Safety, Maintenance, Calibration & Practices manuals.

Required elements (at least one) (Not included):

- MEMT-1. Radial Pressure Distribution in a Journal Bearing.
- MEMT-2. Dynamic Friction of a Cylinder on a Roller.
- MEMT-3. Dynamic Friction of a Pin on a Disc.
- MEMT-4. Rolling Friction in Wheels.
- MEMT-5. Elastohydrodynamic Lubrication.
- MEMT-6. Friction Vibration.



MEMT-UB detail

Required elements (at least one) (Not included):

MEMT-1. Radial Pressure Distribution in a Journal Bearing.

Bench-top unit.
Anodized aluminum frame and panels made of painted steel.
Diagram in the front panel with distribution of the elements similar to the real one.
All elements of this unit are mounted on a base plate to be mounted and connected to the Drive Unit for Tribological Tests, "MEMT-UB".

Journal bearing:
Material: Stainless steel.
Diameter: 50 mm.
Length: 50 mm approx.
Operating speed: 0 – 250 rpm.

Bearing housing:
Material: Transparent methacrylate.
Diameter: 52.5 mm.
Thirteen measuring points around the circumference of the bearing housing.
Movable bearing housing by means of micrometer screw.

Micrometer screw:
Adjustable bearing gap, range: 0 – 2.5 mm.
Graduations: 0.01 mm.

Thirteen tube manometers to indicate the radial pressure distribution in the journal bearing:
Length: 1000 mm.

Lubricant tank.
Thickness gauge to measure the width gap.

Easy connection to the Drive Unit for Tribological Tests, "MEMT-UB".

Cables and accessories, for normal operation.

Manuals: Required services, Assembly and Installation, Interface and Control Software, Starting-up, Safety, Maintenance, Calibration & Practices manuals.

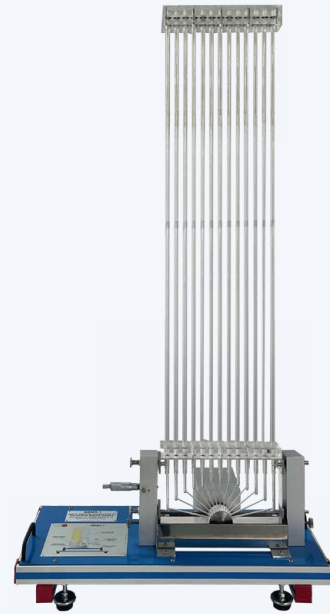

MEMT-1

MEMT-2. Dynamic Friction of a Cylinder on a Roller

Bench-top unit.
Anodized aluminum frame and panels made of painted steel.
Diagram in the front panel with distribution of the elements similar to the real one.
All elements of this unit are mounted on a base plate to be mounted and connected to the Drive Unit for Tribological Tests, "MEMT-UB".

Two levers:
Material: Stainless steel.
Load: 2.5 Kg max approx.

Rotating friction disc:
Material: Tempered steel.
Diameter: 47 mm approx.
Adjustable operating speed, range: 0 – 0.5 m/s.
There is a lubricant tank underneath the rotating disc to vary the lubrication conditions.

Friction pins:
Material: Six steel cylindrical test pieces, six aluminum cylindrical test pieces and six brass cylindrical test pieces.
Diameter: 13 mm.
Length: 25 mm.

Force sensor to measure the friction forces on the levers joint, range: 0 – 50 Kg.
The pressure adjustment is performed using a two lever system and the set of weights.

Set of weights:
Material: Stainless steel.
2 x 1000 g.
1 x 500 g.

Chronometer.

Easy connection to the Drive Unit for Tribological Tests, "MEMT-UB".

Cables and accessories, for normal operation.

Manuals: Required services, Assembly and Installation, Interface and Control Software, Starting-up, Safety, Maintenance, Calibration & Practices manuals.



MEMT-2

Required elements (at least one) (Not included):

MEMT-3. Dynamic Friction of a Pin on a Disc.

Bench-top unit.

Anodized aluminum frame and panels made of painted steel.

Diagram in the front panel with distribution of the elements similar to the real one.

All elements of this unit are mounted on a base plate to be mounted and connected to the Drive Unit for Tribological Tests, "MEMT-UB".

Rotating friction disc:

Material: Hardened and ground stainless steel.

Adjustable operating speed, range: 0 – 0.5 m/s.

The disc is enclosed in an open tank that can be filled with different lubricants to vary the lubrication conditions.

Three friction pins:

Material: Steel, aluminum and brass.

Diameter: 4 mm.

Force sensor to measure the friction forces in the bearing point of the loading mechanism. This force is measured by a force sensor, range: 0 – 50 N.

Set of weights:

Material: Stainless steel.

3 x 20 N.

2 x 10 N.

2 x 5 N.

It includes a weight holder.

The pressure adjustment is performed using a lever and the set of weights.

Easy connection to the Drive Unit for Tribological Tests, "MEMT-UB".

Cables and accessories, for normal operation.

Manuals: Required services, Assembly and Installation, Interface and Control Software, Starting-up, Safety, Maintenance, Calibration & Practices manuals.



MEMT-3

MEMT-4. Rolling Friction in Wheels

Bench-top unit.

Anodized aluminum frame and panels made of painted steel.

Diagram in the front panel with distribution of the elements similar to the real one.

All elements of this unit are mounted on a base plate to be mounted and connected to the Drive Unit for Tribological Tests, "MEMT-UB".

Two rotating friction discs:

Material: Aluminum/rubber.

Diameter: 55 mm approx.

Gearbox to maintain constant the slip between the rotating discs.

Tank for supplying lubricant to vary the lubrication conditions.

Set of weights:

Material: Stainless steel.

1 x 20 N.

1 x 10 N.

2 x 5 N.

It includes a weight holder.

The pressure adjustment is performed using a lever with a mechanical advantage of 2:1 and a set of weights. The contact pressure can be adjusted up to max. 90 N.

Force sensor to measure the friction forces, range: 0 – 50 N.

Easy connection to the Drive Unit for Tribological Tests, "MEMT-UB".

Cables and accessories, for normal operation.

Manuals: Required services, Assembly and Installation, Interface and Control Software, Starting-up, Safety, Maintenance, Calibration & Practices manuals.

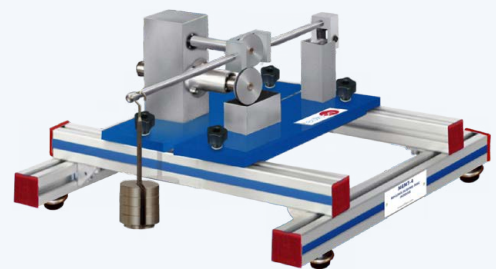

MEMT-4

MENT-5. Elastohydrodynamic Lubrication

Bench-top unit.

Anodized aluminum frame and panels made of painted steel.

Diagram in the front panel with distribution of the elements similar to the real one.

All elements of this unit are mounted on a base plate to be mounted and connected to the Drive Unit for Tribological Tests, "MENT-UB".

Rolling sphere:

Material: Polished and hardened stainless steel.

Diameter: 26 mm approx.

Driven glass disc:

Diameter: 160 mm approx.

Coating: BK-7 dielectric.

Microscope:

Magnification: 50 X.

It can be adjusted using a movable support, adjustable in x-y and has a focus adjustment.

Force sensor, range: 0 – 50 N.

Easy connection to the Drive Unit for Tribological Tests, "MENT-UB".

Cables and accessories, for normal operation.

Manuals: Required services, Assembly and Installation, Interface and Control Software, Starting-up, Safety, Maintenance, Calibration & Practices manuals.



MENT-5

MENT-6. Friction Vibration

Bench-top unit.

Anodized aluminum frame and panels made of painted steel.

Diagram in the front panel with distribution of the elements similar to the real one.

All elements of this unit are mounted on a base plate to be mounted and connected to the Drive Unit for Tribological Tests, "MENT-UB".

Friction ring:

Material: Stainless steel.

Outside diameter: 85 mm approx.

Inside diameter: 65 mm approx.

Adjustable operating speed, range: 0 – 0.8 m/s.

The disc is enclosed in an open tank that can be filled with different lubricants.

Set of weights to load on the friction disc:

Material: Stainless steel.

4 x 10 N.

2 x 5 N.

Force sensor to measure the friction forces. This force is measured by a force sensor, range: 0 – 50 N.

A cord is coupled to force measuring devices with the via a tension spring.

Easy connection to the Drive Unit for Tribological Tests, "MENT-UB".

Cables and accessories, for normal operation.

Manuals: Required services, Assembly and Installation, Interface and Control Software, Starting-up, Safety, Maintenance, Calibration & Practices manuals.

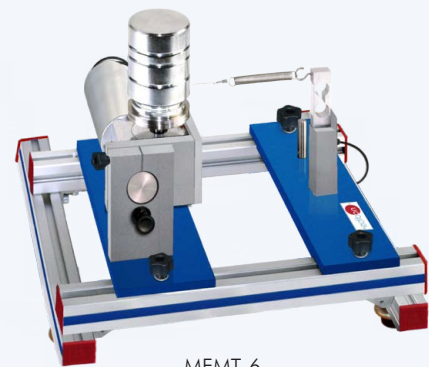

MENT-6

Practices to be done with the experimental unit of Radial Pressure Distribution in a Journal Bearing (MEMT-1):

- 1.- Demonstration and visualization of the radial pressure distribution in a journal bearing with hydrodynamic lubrication.
- 2.- Investigation of the pressure distribution in the journal bearing depending on the bearing gap width.
- 3.- Investigation of the pressure distribution in the journal bearing depending on the speed.
- 4.- Study of the stability limit as a function of the gap width.

Practices to be done with the experimental unit of Dynamic Friction of a Cylinder on a Roller (MEMT-2):

- 5.- Demonstration of friction forces between several pins of different materials and a rotating friction disc under different lubrication conditions.
- 6.- Investigation of the friction forces for several pairs of friction materials.
- 7.- Investigation of the friction forces for different speeds of the rotating disc.
- 8.- Investigation of the friction forces with several loads.
- 9.- Investigation of the friction forces for different lubrication conditions.
- 10.-Study of the wear coefficient for different friction parameters.
- 11.-Study of the wear and wear rate for different friction parameters.

Practices to be done with the experimental unit of Dynamic Friction of a Pin on a Disc (MEMT-3):

- 12.-Study of the friction forces between several vertical pins of different materials and a rotating friction disc.
- 13.-Investigation of the friction forces for several pairs of friction materials.
- 14.-Investigation of the friction forces for several loads.
- 15.-Investigation of the friction forces with different lubricants.
- 16.-Investigation of the friction forces at different speeds of the rotating disc.
- 17.-Study of the wear for different friction parameters.

Practices to be done with the experimental unit of Rolling Friction in Wheels (MEMT-4):

- 18.-Determination of the slip forces between two rotating discs in contact.
- 19.-Investigation of friction forces as a function of the load.
- 20.-Investigation of friction forces as a function of the operating speed.
- 21.-Investigation of friction forces as a function of the lubrication.

Practices to be done with the experimental unit of Elastohydrodynamic Lubrication (MEMT-5):

- 22.-Study of the elastohydrodynamic behavior of a lubricant film between a rolling sphere and a disc.
- 23.-Determination of the lubricant film thickness at the point of contact between a sphere and a disc.
- 24.-Comparison of the experimental lubricant film thickness with theoretical values.
- 25.-Study of the influence of load on the lubricant film thickness.
- 26.-Study of the influence of speed on the lubricant film thickness.

Practices to be done with the experimental unit of Friction Vibration (MEMT-6):

- 27.-Demonstration of the transition from static friction to sliding friction.
- 28.-Study of the influence of lubrication on stick-slip effects.
- 29.-Study of the influence of the force between the components on the stick-slip effects.
- 30.-Study of the influence of the relative speed of the components on the stick-slip effects.

REQUIRED SERVICES

- Electrical supply: single-phase 200 VAC – 240 VAC/50 Hz or 110 VAC – 127 VAC/60 Hz.

DIMENSIONS AND WEIGHTS

MEMT:

MEMT-UB. Drive Unit for Tribological Tests.

- Dimensions: 550 x 500 x 280 mm approx.
(21.65 x 19.68 x 11.02 inches approx.)
- Weight: 12 Kg approx.
(26.45 pounds approx.)

MEMT-1:

- Dimensions: 350 x 150 x 500 mm approx.
(13.77 x 5.90 x 19.68 inches approx.)
- Weight: 9 Kg approx.
(19.84 pounds approx.)

MEMT-2:

- Dimensions: 600 x 180 x 200 mm approx.
(23.62 x 7.08 x 7.87 inches approx.)
- Weight: 9 Kg approx.
(19.84 pounds approx.)

MEMT-3:

- Dimensions: 400 x 450 x 230 mm approx.
(15.74 x 17.71 x 9.05 inches approx.)
- Weight: 8 Kg approx.
(17.63 pounds approx.)

MEMT-4:

- Dimensions: 500 x 280 x 150 mm approx.
(19.68 x 11.02 x 5.90 inches approx.)
- Weight: 11 Kg approx.
(24.25 pounds approx.)

MEMT-5:

- Dimensions: 350 x 250 x 600 mm approx.
(13.78 x 9.84 x 23.62 inches approx.)
- Weight: 12 Kg approx.
(26.45 pounds approx.)

MEMT-6:

- Dimensions: 400 x 100 x 190 mm approx.
(15.74 x 3.93 x 7.48 inches approx.)
- Weight: 8 Kg approx.
(17.63 pounds approx.)

Electronic console:

- Dimensions: 300 x 190 x 130 mm approx.
(11.81 x 7.48 x 5.11 inches approx.)
- Weight: 3 Kg approx.
(6.61 pounds approx.)

REQUIRED ELEMENTS (Not included)

Required (at least one):

- MEMT-1. Radial Pressure Distribution in a Journal Bearing.
- MEMT-2. Dynamic Friction of a Cylinder on a Roller.
- MEMT-3. Dynamic Friction of a Pin on a Disc.
- MEMT-4. Rolling Friction in Wheels.
- MEMT-5. Elastohydrodynamic Lubrication.
- MEMT-6. Friction Vibration.

ADDITIONAL RECOMMENDED ELEMENTS (Not included)

- Hydraulic oil: 80w90.

MEMT/ICAI. Interactive Computer Aided Instruction Software:

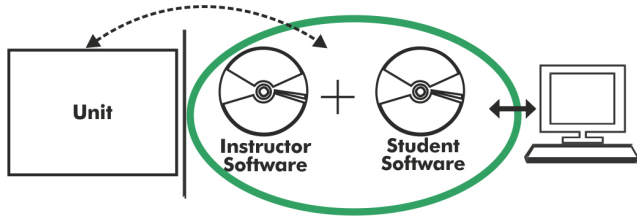

With no physical connection between unit and computer, this complete software package consists of an Instructor Software (EDIBON Classroom Manager -ECM-SOF) totally integrated with the Student Software (EDIBON Student Labsoft -ESL-SOF). Both are interconnected so that the teacher knows at any moment what is the theoretical and practical knowledge of the students.

Instructor Software

- ECM-SOF. EDIBON Classroom Manager (Instructor Software).

ECM-SOF is the application that allows the Instructor to register students, manage and assign tasks for workgroups, create own content to carry out Practical Exercises, choose one of the evaluation methods to check the Student knowledge and monitor the progression related to the planned tasks for individual students, workgroups, units, etc... so the teacher can know in real time the level of understanding of any student in the classroom.

Innovative features:

- User Data Base Management.
- Administration and assignment of Workgroup, Task and Training sessions.
- Creation and Integration of Practical Exercises and Multimedia Resources.
- Custom Design of Evaluation Methods.
- Creation and assignment of Formulas & Equations.
- Equation System Solver Engine.
- Updatable Contents.
- Report generation, User Progression Monitoring and Statistics.

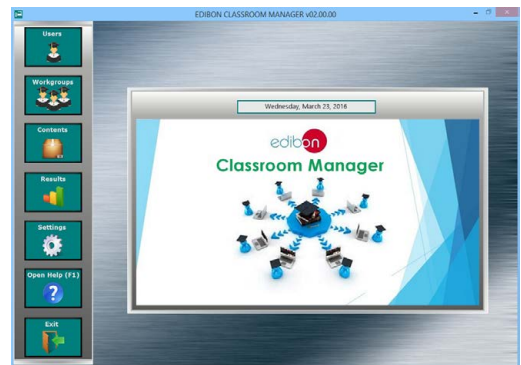

ECM-SOF. EDIBON Classroom Manager (Instructor Software) Application Main Screen

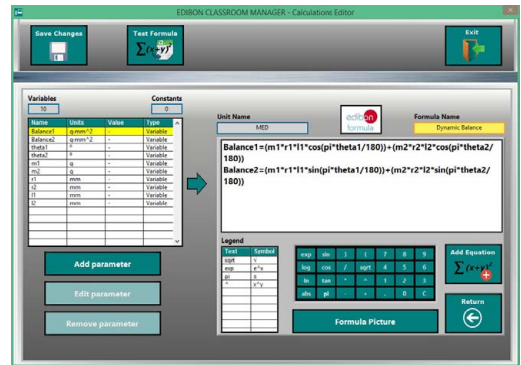

ECAL. EDIBON Calculations Program Package - Formula Editor Screen

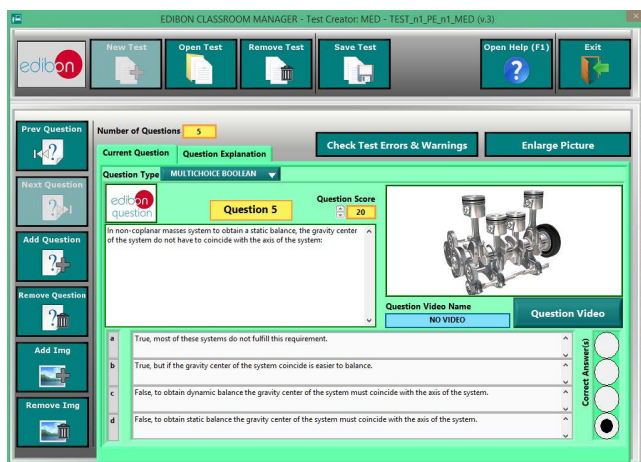

ETTE. EDIBON Training Test & Exam Program Package - Main Screen with Numeric Result Question

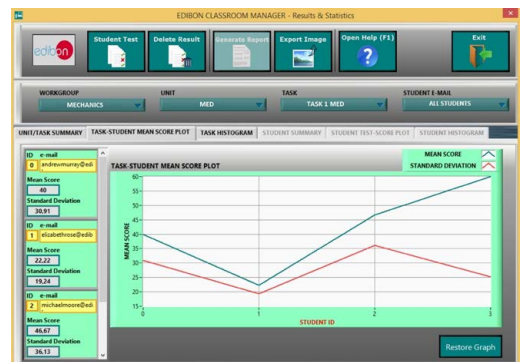

ERS. EDIBON Results & Statistics Program Package - Student Scores Histogram

Optional
Student Software

- **ESL-SOF. EDIBON Student Labsoft (Student Software).**

ESL-SOF is the application addressed to the Students that helps them to understand theoretical concepts by means of practical exercises and to prove their knowledge and progression by performing tests and calculations in addition to Multimedia Resources. Default planned tasks and an Open workgroup are provided by EDIBON to allow the students start working from the first session. Reports and statistics are available to know their progression at any time, as well as explanations for every exercise to reinforce the theoretically acquired technical knowledge.

Innovative features:

- Student Log-In & Self-Registration.
- Existing Tasks checking & Monitoring.
- Default contents & scheduled tasks available to be used from the first session.
- Practical Exercises accomplishment by following the Manual provided by EDIBON.
- Evaluation Methods to prove your knowledge and progression.
- Test self-correction.
- Calculations computing and plotting.
- Equation System Solver Engine.
- User Monitoring Learning & Printable Reports.
- Multimedia-Supported auxiliary resources.

For more information see ICAI catalogue. Click on the following link:
www.edibon.com/en/interactive-computer-aided-instruction-software



ESL-SOF. EDIBON Student LabSoft (Student Software) Application Main Screen

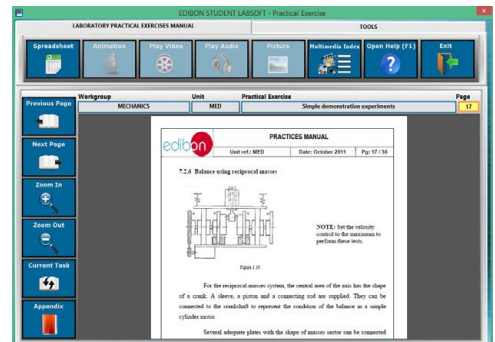

EPE. EDIBON Practical Exercise Program Package Main Screen

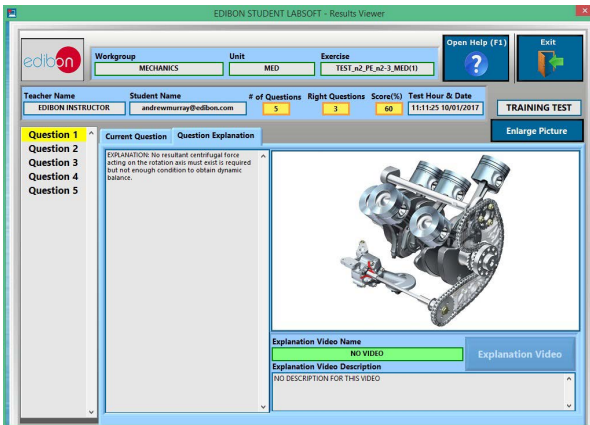

ERS. EDIBON Results & Statistics Program Package - Question Explanation

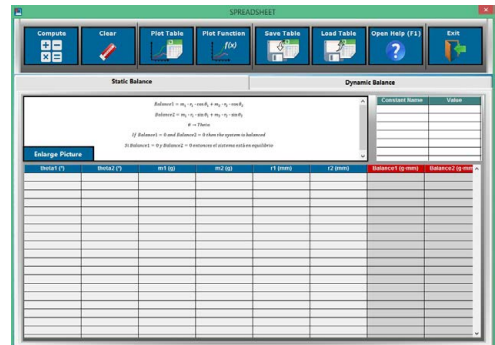

ECAL. EDIBON Calculations Program Package Main Screen

* Specifications subject to change without previous notice, due to the convenience of improvement of the product.



C/ Julio Cervera, 10-12-14. Móstoles Tecnológico.
28935 MÓSTOLES. (Madrid). ESPAÑA - SPAIN.
Tel.: 34-91-6199363 Fax: 34-91-6198647
E-mail: edibon@edibon.com Web: www.edibon.com

Edition: ED01/23
Date: March/2023

REPRESENTATIVE:

